

1. Introduction .....	1
1.1 Statement .....	1
1.2 Implications of Abbreviations .....	1
2. Safety Instructions .....	1
2.1 Important Reminder .....	1
2.2 Requirements for Specification .....	2
2.3 Personnel Safety .....	3
2.4 Personnel Requirements .....	4
2.5 Electrical Safety .....	4
2.5.1 Earthing Requirements .....	5
2.5.2 Installation Environment Requirements .....	5
2.5.3 Installation Notes .....	6
2.6 Warning Label .....	7
3. Product Introduction .....	8
3.1 Product Overview and Features .....	8
3.2 Appearance Description .....	8
3.2.1 Appearance Introduction .....	9
3.2.2 Port Function Description .....	10
3.2.3 Description of Energy Storage Capacity .....	10
3.3 Working Principle and Function .....	10
4. Installation Matters .....	11
4.1 Check before Installation .....	11
4.2 Tool and Labor Insurance .....	11
4.3 Selection of Installation Location .....	12
4.3.1 Basic Requirements .....	12
4.3.2 Requirements for the Installation Space .....	12
4.4 Equipment Installation .....	13
5. Electrical Connection .....	14
5.1 Electrical Connection of the Energy Storage Battery .....	15

5.2 Battery Module Address Setting .....	15
5.3 LED Indication Function .....	16
5.3.1 Capacity Indicator .....	18
5.3.2 LED Flashing Instructions .....	18
5.4 Battery Status Mode .....	19
6. Electrical Specification and BMS .....	19
6.1 Electrical Specification .....	19
6.2 BMS .....	20
6.2.1 BMS System Schematic Diagram .....	20
6.2.2 BMS Parameter .....	21
7. Equipment Acceptance .....	21
7.1 Acceptance Standard .....	21
8. Routine Maintenance and Storage of Batteries .....	22
8.1 Battery System Maintenance .....	22
8.2 Routine Maintenance .....	23
8.3 Battery Storage .....	23
8.4 Battery Module Data .....	25
9. Accessories and Warranty Cards .....	26
9.1 Accessories .....	26
9.2 Warranty Card .....	27
Maintenance Record .....	27

# 1. Introduction

## 1.1 Statement

Thanks a lot for choosing stacked inverter integrated ZC-S51100 series energy storage system from Changxing Liheng New Energy Technology Co., Ltd. (hereinafter referred to as “Liheng New Energy”). This manual will provide detailed product information and installation instructions for users who use Liheng New Energy's stacked inverter integrated ZC-S51100 series energy storage system. Please read all instructions and precautions in the manual carefully before installation and use. If you have any suggestions during use, please feel free to give us feedback. Liheng New Energy will not notify users of any modification to this manual.

The drawings provided in this manual are used to explain product-related concepts, including product information, installation guidelines, electrical connections, system commissioning, safety information, common problems and maintenance, etc.

## 1.2 Implications of Abbreviations

AC	Alternating Current
DC	Direct Current
PV	Photovoltaic
BMS	Battery Management System
PCS	Power Conversion System
RJ45	RJ45 Modular Plug
SOC	State of Charge
C	Current-Rate
RS485	Recommended Standard 485
CAN	Controller Area Network

# 2. Safety Instructions

## 2.1 Important Reminder

Before installing, operating and maintaining the equipment, please read this

manual first, and follow the symbols on the equipment and all safety precautions in this manual. For safety, it is the installer's responsibility to familiarize himself with this manual and all warnings prior to installation.

Items marked with "danger" and "attention" in this manual do not represent all safety items to be observed, but are only supplements to all safety precautions. Liheng New Energy is not responsible for any violation of general safety operation requirements, or Any operation that violates equipment design, production and use safety standards. The device must be used in an environment that meets the requirements of the design specification. Otherwise, the equipment may malfunction, and the resulting abnormal equipment function or component damage, personal safety accidents and property losses are not within the scope of equipment quality assurance. Local laws, regulations and norms should be followed while installing, operating and maintaining equipment. The safety precautions in this manual are only a supplement to local laws, regulations and norms. In any of the following circumstances, Liheng New Energy shall not be liable:

- 1) The equipment is not performed under the operating conditions described in this manual;
- 2) The installation and operation environment exceeds the requirements of the relevant international or national standards;
- 3) Disassemble, modify or modify the software code of the products without authorization;
- 4) Failure to comply with the operating instructions and safety warnings related to the product and documents;
- 5) Equipment damage caused by abnormal natural environment (earthquake, fire, storm and other force majeure);
- 6) The transportation damage caused by the customer during the transportation;
- 7) The storage conditions do not meet the requirements of relevant product documents and cause damage;
- 8) Failure to observe the safety precautions and rules in this operating instruction and document.

## **2.2 Requirements for Specification**

- 1) Live operation is forbidden during the installation;
- 2) It is strictly forbidden to install, use and operate any outdoor equipment and

- cables in harsh environments(including but not limited to transportation equipment, operating equipment and cables, plugging and removing signal ports connected to the outdoor, working at heights, outdoor installation). Thunder, rain, snow, strong wind and other six-level weather;
- 3) In any case, without the permission of the manufacturer, the structure and installation sequence of the equipment shall not be changed;
  - 4) The battery terminal assembly shall not be affected during transportation;
  - 5) It is strictly forbidden to alter, damage or cover the signs and nameplates on the equipment;
  - 6) Fully understand the composition and working principle of the entire photovoltaic power generation system, as well as the relevant standards of the country/region where the project is located;
  - 7) After the equipment is installed, the empty packaging materials in the equipment area should be removed, such as cartons, foam, plastic, cable ties, etc.

## **2.3 Personnel Safety**

- 1) Wear appropriate personal protective equipment when operating equipment. If a failure that may cause personal injury or equipment damage is found, the operation should be stopped immediately;
- 2) Before using any tools, please understand the correct use of tools to avoid injury and equipment damage;
- 3) When the equipment is running, the shell temperature is high, which may cause burns. Therefore, do not touch the case;
- 4) In order to ensure personal safety and normal use, reliable grounding should be conducted before use;
- 5) Do not open or damage the battery, the released electrolyte is harmful to the skin and eyes, so avoid touching it;
- 6) Do not place unrelated items on the top of the equipment or insert them into any part of the equipment;
- 7) Do not place flammable items around the equipment;
- 8) Do not put the battery into fire, so as not to explode and prevent personal safety from being endangered;
- 9) Do not place the battery module in water or other liquids;

- 10) Do not short-circuit the battery terminal, otherwise the battery short-circuit may cause an explosion;
- 11) The battery may cause the danger of electric shock and large short-circuit currents. Some matters should be noted when using the battery:
  - a) Watches, rings and other metal items should be removed;
  - b) Tools with insulated handles shall be used;
  - c) Rubber gloves and shoes shall be worn;
  - d) Disconnect the charging power supply before connecting or disconnecting the battery terminal;
  - e) Check the battery for accidental grounding, and if so, unplug the power supply from the ground wire.
- 12) Do not clean the internal and external electrical components of the cabinet with water or detergent;
- 13) Do not stand, lean, or sit on the equipment;
- 14) Do not damage any modules of the equipment.

## **2.4 Personnel Requirements**

- 1) The personnel responsible for installation and maintenance must undergo strict training, understand all safety precautions and master the correct operation methods;
- 2) Only qualified professionals or trained personnel are allowed to install, operate, and maintain the equipment;
- 3) Personnel operating the equipment, including operators, trained personnel and professionals, must have special operation qualifications required by the local country, such as high-pressure operation, high-altitude operation, special equipment operation qualifications and, etc;
- 4) Replacement of equipment or components(including software) must be operated by professional or authorized personnel.

## **2.5 Electrical Safety**

- 1) Before electrical connections, please make sure that the equipment is not damaged, otherwise it may cause electric shock or fire;

- 2) Do not install or remove any power cord when power up. Arcing or sparks may be generated when the power cord is in contact with a conductor, which may cause fire or personal injury;
- 3) All electrical connections must comply with the national electrical standards where the project is located;
- 4) The cables provided by the user shall comply with the local laws and regulations;
- 5) Special insulation tools shall be used for high-voltage operation;
- 6) Make sure that the identification on the power cord is correct before connecting the power cord;
- 7) The equipment can only be operated after 5 minutes when the device is completely powered off;
- 8) When the cables are used in a high temperature environment, the insulation layer of the cable may be aged or damaged. Therefore, the distance between the cable and the heat source must be at least 30mm;
- 9) Cables of the same type shall be tied together, and the wiring time distance of different types of cables shall be at least 30mm, without winding or crossing.

### **2.5.1 Earthing Requirements**

- 1) When installing equipment that needs to be grounded, the protective ground wire must be installed first; when dismantling the equipment, the protective grounding wire must be removed last;
- 2) Do not destroy the grounding conductor;
- 3) It is forbidden to operate the equipment without installing the grounding conductor;
- 4) The equipment should be permanently connected to ground wire. Before operating the equipment, check the electrical connection of the equipment to ensure that the equipment is reliably grounded.

### **2.5.2 Installation Environment Requirements**

- 1) This product is only for indoor use, it is strictly prohibited to use in the outdoor environment;
- 2) Do not install or use this product in temperatures below  $-10^{\circ}\text{C}$  or above  $50^{\circ}\text{C}$ ;

- 3) Should be installed in a dry, well-ventilated environment to ensure good heat dissipation performance;
- 4) The product can be installed at an altitude of 2000m above sea level;
- 5) The installation position should be far away from the fire source;
- 6) Keep away from children and animals during installation and use;
- 7) The installation position should be far away from the faucet, sewer, nozzle and other water sources, to avoid water intake;
- 8) The equipment shall be placed on a firm and flat supporting surface;
- 9) Do not place any inflammable and explosive items around the equipment;
- 10) Do not block the vent and heat dissipation system to prevent fire caused by high temperature when the equipment is running.

### **2.5.3 Installation Notes**

Before installation, please read this manual carefully and be familiar with the installation steps.











- 1) Avoid putting metal objects near the battery to prevent short circuit;
- 2) Acid gas may be generated while charging, so ensure that the environment is well ventilated;
- 3) When installing the cabinet, be sure to leave enough space around the all-in-one machine for heat dissipation; do not install the all-in-one machine and lead-acid liquid battery in the same cabinet to avoid corrosion of the all-in-one machine by the acid gas generated when the battery is working;
- 4) Only charge the type of battery that matches this all-in-one machine;
- 5) The weak connection point and the corroded wire may cause great heat to melt the wire insulation layer, burn the surrounding materials, and even cause fire, so to ensure that the connector is tightened, the wire is best fixed with a tie belt, to avoid the wire shaking and loose connector during the mobile application;
- 6) The system connection cable is selected according to a current density of no more than 5A/mm<sup>2</sup>;
- 7) Avoid direct sunlight and rain infiltration during outdoor installation;
- 8) After the switch of the power supply is turned off, there is still high voltage inside the all-in-one machine. Do not open or touch the internal devices, and carry out the relevant operation after the capacitor is discharged;
- 9) Do not install the all-in-one machine in damp, greasy, flammable, explosive, large



amount of dust and any other severe environment;

- 10) The polarity of the battery input terminal of this product is forbidden to be reversed. Otherwise, it is easy to damage the equipment or cause unpredictable dangers;
- 11) Mains input and AC output are high voltage, please do not touch the wiring point;
- 12) Do not touch the fan while working to prevent injury;
- 13) For the input power of the load equipment, it must be confirmed that this all-in-one machine is the only input device, and it is forbidden to use it in parallel with other input AC power sources to avoid damage.

## 2.6 Warning Label

Symbol	Description
	Trash bin forbidden
	Recyclable
	EU Regional Certification
	Electric shock hazard
	Explosive gas
	Alternating current
	Dangerous weight
	Away from babies
	Ensure good connection
	No open flames
	Follow the manual

## **3. Product Introduction**

### **3.1 Product Overview and Features**

ZC-S51100 is a new generation of household energy storage system, which has the function of customizing the power storage module and can meet the diversified needs of global users. ZC-S51100 adopts modular design, including power module and battery expansion module, so it can be easily combined into any capacity system required by users.

The energy storage module adopts high performance and long life lithium iron phosphate battery. Meanwhile, each module consists of 16 100Ah cells connected in series into a 51.2V voltage battery module. Two to fifteen modules can be connected in parallel to expand the capacity and power of the energy storage system. A modular structural design was used. Each energy storage module is integrated with a BMS system, which can be easily expanded and combined with up to 75Kwh battery pack.

The power module adopts a new topological circuit design, which can realize the energy conversion before photovoltaic, mains, battery and load, and has photovoltaic and mains charging functions, with a wide voltage range. The mains charging module adopts advanced control algorithm to realize full digital double closed-loop control of voltage and current. High control accuracy, small volume. AC voltage input range is wide, the input and output protection function is complete, can achieve stable and reliable battery charging and protection. The inverter module is based on full digital intelligent design, adopts advanced SPWM technology, output pure sine sinusoidal wave, and convert direct current into alternating current, which is suitable for household appliances, power tools and other AC loads. Specifically, the energy storage battery system supplies the load through PCS when there is no solar energy at night; when solar energy is available during the day, solar power preferentially powers the load and the remaining solar energy is stored in the battery system.

### **3.2 Appearance Description**

The ZC-S51100 consists of battery module base, battery module (including cell

and shell parts), battery management system (BMS), PCS and communication terminal. Product appearance is shown in the figure below:

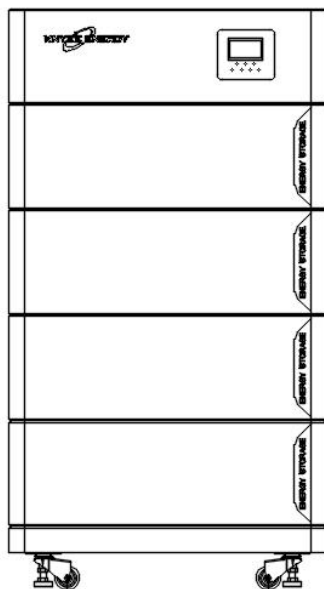

### 3.2.1 Appearance Introduction

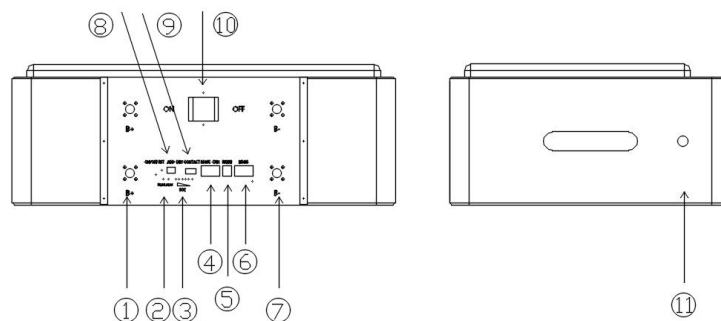

NO.	Explain
①	Battery Positive
②	LED(RUN/ALARM)
③	LED
④	RS485/CAN
⑤	RS232
⑥	RS485/RS485
⑦	Battery Negative
⑧	Address
⑨	Dry Contact
⑩	Air Circuit-breaker
⑪	Battery ON/OFF

### 3.2.2 Port Function Description

Port	Function
Communication Interface	PCS RS485-2 Communication
	LINK-IN Communication
	LINK-OUT Communication
Safety Vents	Balance the Air Pressure and Adjust the Temperature
Negative Terminal	PACK B- Representative of the PACK B-
Earth Terminal	Terminal Ground
Positive Terminal	PACK B+ Representative of the PACK B+
Lamp Panel	SOC and Status Display
Power Button	Start Stop

### 3.2.3 Description of Energy Storage Capacity

This series of energy storage systems supports the expansion of up to 4 energy storage modules.

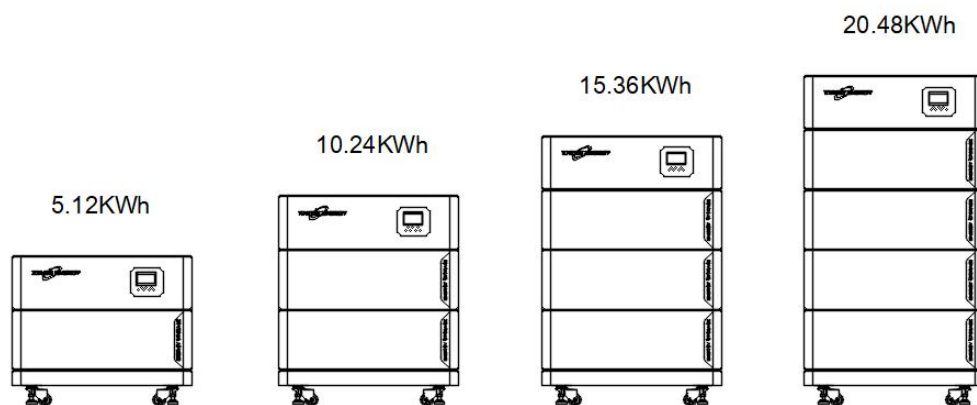

### 3.3 Working Principle and Function

ZC-S51100 is an energy storage unit composed of electrochemical batteries, switch buttons, battery management unit, power supply and signal terminals, and mechanical components. Compared with other batteries, it has better charge and discharge performance, more accurate state monitoring, longer cycle life, and less self-discharge loss. With 2-15 packs in parallel to increase the capacity and power of

the battery system; The entire battery system communicates with the Power Conversion System (PCS) via the RS485-2.

The battery module has three working modes of mains power priority mode, inverter priority mode and photovoltaic priority mode, which are suitable for different power consumption environments. The factory default setting is mains priority mode.

Mains priority mode: switch to inverter only when the mains is invalid.

Inverter priority mode: switch to mains only when the battery is undervoltage or lower than the parameter setting value.

Photovoltaic priority mode: switch to mains only when the photovoltaic is invalid or the battery is lower than the parameter setting value.





## 4. Installation Matters

### 4.1 Check before Installation

**Packing Inspection:** Before opening the packaging of the energy storage, inspect the outer packaging for any visible damage, such as holes, cracks, or other signs of possible internal damage, and check the type of energy storage. If there is any abnormality in the packaging or the energy storage model is inconsistent, please do not open it and contact us as soon as possible.

**Inspect the deliverables:** After opening the outer packaging of the energy storage, check whether the delivery is complete and whether there is any obvious external damage. If any items are missing or damaged, please contact us.

### 4.2 Tool and Labor Insurance

Type	Tool/Labor Security		
Installation Tool			
			

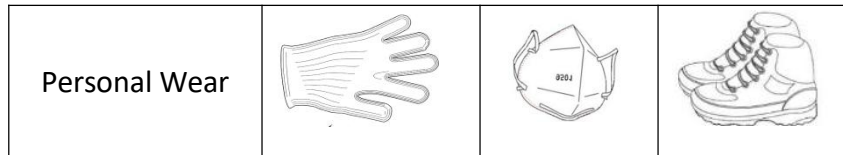

## 4.3 Selection of Installation Location

### 4.3.1 Basic Requirements

- 1) When the energy storage runs, the temperature of the cabinet and the radiator will be very high. Therefore, please do not install it where it is easy to touch;
- 2) Do not install near the place where flammable and explosive materials are stored;
- 3) If an energy storage device is installed in a salty area, it will be corroded and may cause a fire. Therefore, do not install it in outdoor areas with salt damage. Salt damage area is defined as the area below 500m from the coast or affected by sea breeze. The area affected by sea breeze varies depending on meteorological conditions(such as typhoon, monsoon) or topographical conditions(dam, hill).
- 4) Do not install where accessible to children;
- 5) Goggles and protective gloves shall be worn when drilling in walls or ground;
- 6) When drilling, the equipment should be shielded to prevent debris from falling into the equipment. After the drilling process, the debris should be cleaned up in time;
- 7) When carrying heavy objects, you should be prepared to bear the heavy objects so as not to be crushed or sprained;
- 8) When operating the equipment by hand, wear protective gloves to avoid injury.

### 4.3.2 Requirements for the Installation Space

When installing the energy storage equipment, some space should be left around it to ensure that there is enough space for installation and heat dissipation.

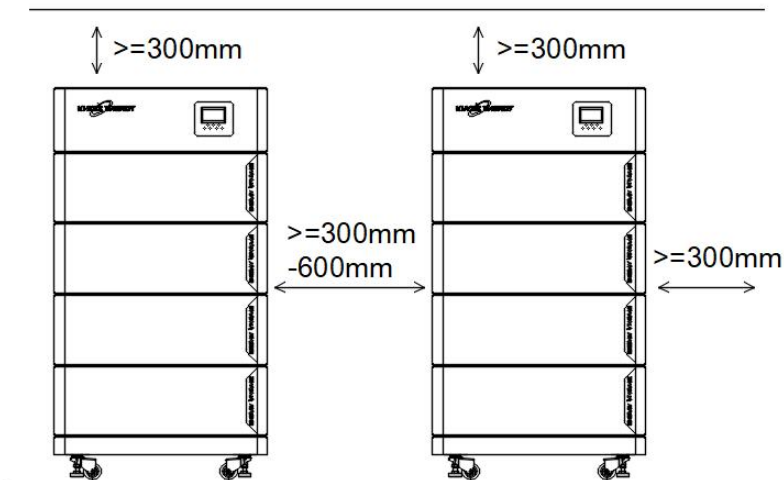

#### 4.4 Equipment Installation

The battery fixed base should be placed in the appropriate position, the installation site should be smooth, the ground is solid, and the equipment should be 30-50cm from the wall.

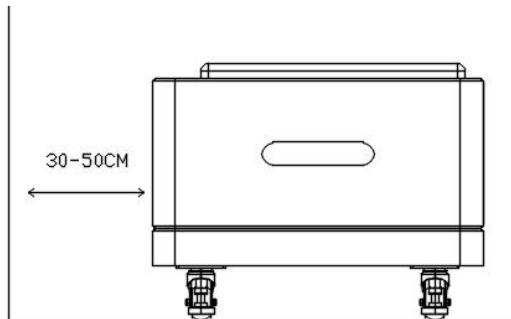

If there are multiple batteries, place the first battery correctly before placing the other batteries.

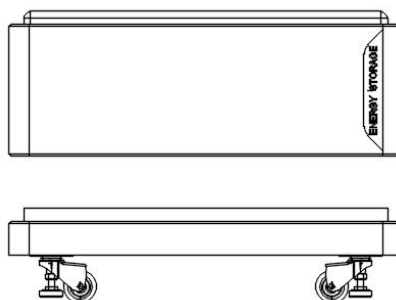

The installation personnel should pay attention to the direction during the installation process. They shall be mounted vertically and not tilted.

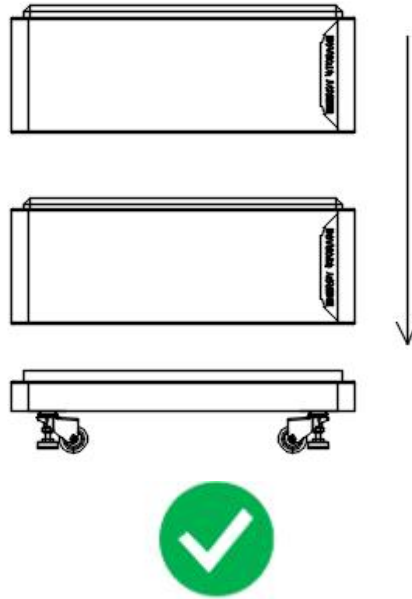

The PCS module shall be installed at the top rather than other locations.

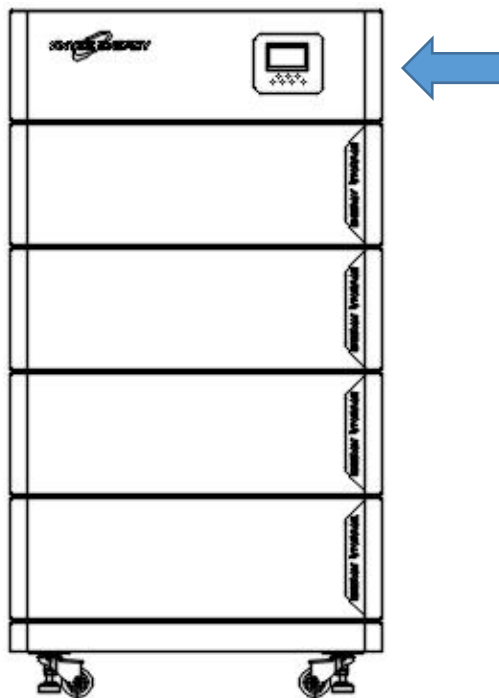

## 5. Electrical Connection

Before electrical connection, ensure that the switches of the energy storage and the power module and all switches connected to the energy storage are in "OFF" state and the power module is in "OFF" state. Otherwise, the equipment voltage may be too high.



- 1) Equipment damage caused by wiring error is not within the scope of the equipment warranty;
- 2) The operations related to the electrical connection must be carried out by the professional electrical technicians;
- 3) When making an electrical connection, the operator must wear protective equipment.

## 5.1 Electrical Connection of the Energy Storage Battery

Before connecting the battery module, ensure that the battery is not active and the battery indicator OFF. Use the power cord shipped with the product to connect the positive and negative electrodes of the other battery or power module. It should be noted that the red cable is connected to the red terminal (positive terminal), and the black cable is connected to the black terminal (negative terminal).

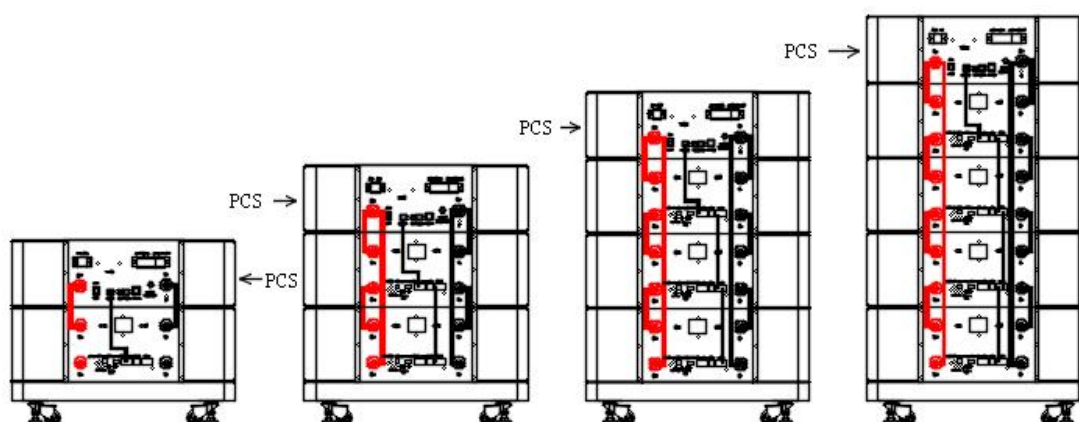

The signal wires shipped with the product are used for connecting the RS485 interface for each battery module, The communication port of the inverter requires a connection to the RS485-2 interface. The PV line should be distinguished between into +/- poles, and correctly distinguish between L/N and grounding when connecting AC input wires and AC output wires to avoid short circuit (reference to inverter instruction manual for inverter wiring).

## 5.2 Battery Module Address Setting

When multiple energy storage battery modules are used in parallel, the address of the energy storage battery module needs to be set. The address is set to 1~4, and

the address of each module cannot be repeated.

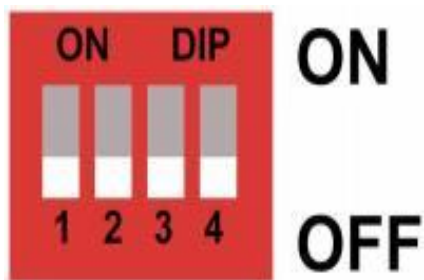

When the battery packs are connected in parallel, the dial code switch of each battery can be used to distinguish different Pack addresses. The hardware address can be set through the dial code switch on the board. The definition of the dial code switch refer to the following table:

ADD	Dial Switch Position				Explain
	#1	#2	#3	#4	
0	OFF	OFF	OFF	OFF	Pack0
1	ON	OFF	OFF	OFF	Pack1
2	OFF	ON	OFF	OFF	Pack2
3	ON	ON	OFF	OFF	Pack3
4	OFF	OFF	ON	OFF	Pack4
5	ON	OFF	ON	OFF	Pack5
6	OFF	ON	ON	OFF	Pack6
7	ON	ON	ON	OFF	Pack7
8	OFF	OFF	OFF	ON	Pack8
9	ON	OFF	OFF	ON	Pack9
10	OFF	ON	OFF	ON	Pack10
11	ON	ON	OFF	ON	Pack11
12	OFF	OFF	ON	ON	Pack12
13	ON	OFF	ON	ON	Pack13
14	OFF	ON	ON	ON	Pack14
15	ON	ON	ON	ON	Pack15

### 5.3 LED Indication Function

The current power consumption and operation status of the product are shown

through LED indicator Light Working status indication.

Status	Normal / warning/ protection	ON/ OFF	RUN	ALM	Battery capacity LED						Specification	
		●	●	●	●	●	●	●	●	●		
Power off	Dormancy	NO	NO	NO	NO	NO	NO	NO	NO	NO	NO	All NO
Ready mode	Normal	YES	Flash1	NO	Indicate according to the battery capacity						Ready mode status	
	Warning	YES	Flash1	Flash3							Module low voltage	
Charging	Normal	YES	YES	NO	Indicate according to the battery capacity( LED 2 flash when it indicate the highest battery capacity)						LED 2 flash when it is highest battery capacity, ALM do not flash when over-charging	
	Warning	YES	YES	Flash3								
	Over charging protection	YES	YES	NO	YES	YES	YES	YES	YES	YES	If there is no mains power, the indicator turns to standby	
	Temperature over current, failure protection	YES	NO	YES	NO	NO	NO	NO	NO	NO	NO	Stop charging
Discharging	Normal	YES	Flash3	NO	Indicate according to the battery capacity							
	Warning	YES	Flash3	Flash3								
	Under voltage protection	YES	NO	NO	NO	NO	NO	NO	NO	NO	NO	Stop discharging
	Over temperature, current, short circuit, reverse connection, failure protection	YES	NO	YES	NO	NO	NO	NO	NO	NO	NO	Stop discharging

Invalidation		NO	NO	YES	NO	NO	NO	NO	NO	NO	NO	Stop charging and discharging
--------------	--	----	----	-----	----	----	----	----	----	----	----	-------------------------------

### 5.3.1 Capacity Indicator

Status		Charging						Discharging					
Capacity dictator		L6	L5	L4	L3	L2	L1	L6	L5	L4	L3	L2	L1
		●	●	●	●	●	●	●	●	●	●	●	●
<b>Battery level (%)</b>	0~16.6%	NO	NO	NO	NO	NO	Flash2	NO	NO	NO	NO	NO	YES
	16.6~33.2%	NO	NO	NO	NO	Flash2	YES	NO	NO	NO	NO	YES	YES
	33.2~49.8%	NO	NO	NO	Flash2	YES	YES	NO	NO	NO	YES	YES	YES
	49.8~66.4%	NO	NO	Flash2	YES	YES	YES	NO	NO	YES	YES	YES	YES
	66.4~83.0%	NO	Flash2	YES	YES	YES	YES	NO	YES	YES	YES	YES	YES
	83.0~100%	Flash2	YES	YES	YES	YES	YES	YES	YES	YES	YES	YES	YES
<b>Working dictator●</b>		YES						Flash 3					

### 5.3.2 LED Flashing Instructions

Flash Way	Bright	NO
Flash 1	0.25S	3.75S
Flash 2	0.5S	0.5S
Flash 3	0.5S	1.5S

Note: The LED indicator alarm can be enabled or disabled through the host computer.

The factory default is enabled.

## 5.4 Battery Status Mode

Sleep Mode: Without RS485/CAN communication, charging/discharging or pressing any buttons, 24h later this power box will enter into sleep mode to save the power, it has small self-consumption;

Awake mode: When the system is in sleep mode, if any of the following requirements, the system will quit the sleep mode and enter into the normal operation mode.

- 1) Automatic wake-up after charged with voltage higher than 48V;
- 2) Press the key button for 3~6 seconds, release the key button and activate it;
- 3) Access communication line (RS232), activate it with upper computer software.

Power-off mode wake-up:

- 1) Charging voltage should be greater than 48V.
- 2) Press the button for 3~6 seconds and release the button.

## 6. Electrical Specification and BMS

### 6.1 Electrical Specification

Unless there is special requirement, the test shall be done under temperature of  $25\pm 2^{\circ}\text{C}$  and with relative humidity of 45~85%.

Items	Test Condition	Standard
Standard Charge	The standard charge means charge the battery in temperature below $25\pm 3^{\circ}\text{C}$ with initial charge current of 20A(100Ah) and with constant voltage of 58.4V, then charge with constant voltage of 58.4V and with floating current taper to 0.5A (100Ah) cut-off (charger should be exclusively designed for lithium battery, with an accuracy of $\pm 0.05\text{V}$ ) within 6 hours.	/
Standard Discharge	After battery is charged fully in accordance with the standard and then discharge to voltage 40V with discharge current of 20A(100Ah).The minimum gap time between charge and discharge	Minimum Capacity $\geq 100\text{Ah}$



## 6.2.2 BMS Parameter

NO.	Item		51.2V100Ah
1	Power Consumption	Low power consumption mode	$\leq 200\mu\text{A}$
2	Over Charge Protection	Over charge detection voltage	3.65V
		Over charge release voltage	3.40V
3	Over Discharge Protection	Over discharge detection voltage	2.75V
		Over discharge release voltage	2.95V
4	Over Current Protection	Discharging over current detection current (detection time)	110A ( 1S)
		Discharging over current detection current 1 (detection time)	110A ( 1S)
		Discharging over current detection current 2 (detection time)	$\geq 150\text{A}$ 100ms
5	Temp. Protection	Detection temperature	$65\pm 2^{\circ}\text{C}$
6	Balance	Balance voltage	3.4V

## 7. Equipment Acceptance

### 7.1 Acceptance Standard

NO.	Acceptance items	Acceptance Standard	Inspect
1	The energy storage battery is installed in place	The installation is correct, stable and safe.	
2	The installation environment meets the requirements	The installation space is reasonable, and the environment is clean and tidy.	
3	Battery power cord is	The positive and negative poles	

	connected correctly	are correctly connected with no omission.	
4	Battery signal wire is connected correctly	The signal wires are correctly connected and reliable.	
5	Reliable grounding	The ground wire is properly and firmly.	
6	All air switches of the power module are turned off	All the air switches are in the "OFF " state.	
7	All battery module switches are turned off	The start switch is in the "OFF" state	

## 8. Routine Maintenance and Storage of Batteries

### 8.1 Battery System Maintenance

After the system is powered off, the shell still has residual power and heat, which may cause electric shock or burns. Therefore, protective gloves should be worn before operating the energy storage system for 5 minutes after the system fails. Before maintaining the energy storage system, make sure that all indicators of the energy storage system are off.

During the operation of the energy storage system, the system cannot be completely powered off only by turning off the switch of the power unit. No maintenance operations can be performed on the energy storage system at this time.

System power-down operation steps:

- ① Disconnect the switch between the power supply unit and the AC output;
- ② Disconnect the switch between the power supply unit and the AC input;
- ③ Disconnect the switch between the power supply unit and the PV unit;
- ④ Close the switch between the power supply unit and the battery pack;
- ⑤ Turn off all energy storage unit switches and press the energy storage key for 3 seconds until all lights are off and the battery is powered on.



## 8.2 Routine Maintenance

Item	Method	Maintenance Interval
Battery appearance inspection	Check the radiator regularly for shielding and dirt regularly; Check the appearance for damage and deformation; Listen to whether there is any abnormal sound during the operation.	Every six months to a year
Battery operation status check	When the device is running, check whether the parameter settings are set correctly.	Every six months
Battery line connection inspection	Check whether the line connection is disconnected or loose; Check whether the cable is damaged, especially whether the protective sleeve of the contact between the cable and the metal surface is cut out; Check that each interface is locked.	Six months after the first commissioning test, and then six months to a year
Battery grounding line check	Check whether the grounding wire is secure.	Six months after the first commissioning test, and then six months to a year

## 8.3 Battery Storage

- 1) When stored, batteries should be placed correctly according to the mark on the box; do not reverse or side;
- 2) When packing stacked battery packs, they should meet the stacking requirements on the outer packaging.
- 3) The battery should be carefully handled, strictly prohibit damage to the battery;
- 4) Requirements for the storage environment:
  - f) Ambient temperature:  $-10^{\circ}\text{C} \sim 55^{\circ}\text{C}$ , recommended storage temperature:  $20^{\circ}\text{C} \sim 30^{\circ}\text{C}$ ;
  - g) Relative humidity: 5%RH-80%RH

- h) Dry, well-ventilated and clean
  - i) Keep away from corrosive organic solvents, gases and other substances;
  - j) Avoid direct sunlight;
  - k) The distance from the heat source should not be less than 2 meters.
- 5) When stored, it should be disconnected from the outside; if there is an indicator light on the battery panel, the indicator light should be off.
  - 6) After the battery is produced and tested, it should be charged to at least 50% SOC before storage; if the device is not used for a long time, the battery should be discharged to 45% ~ 60% of the battery capacity, and the battery output should be disconnected to avoid battery power exhaustion;
  - 7) Do not touch the battery pack with your wet hands;
  - 8) Do not squeeze, fall, or puncture the battery;
  - 9) Batteries should always be disposed of in accordance with local safety regulations;
  - 10) The battery shall be stored and charged as specified in this manual;
  - 11) When storing or transporting the battery, do not reverse the polarity of the battery, batteries must not be stacked without protective packaging, and the number of stacked pack batteries shall not exceed the number specified on the package;
  - 12) All operators of the energy storage system shall follow the user manual, installation and maintenance manual, and quality assurance requirements; Equipment damage caused by ignoring or misreading user manuals, installation and maintenance manuals, and quality assurance requirements will void the product warranty.

## 8.4 Battery Module Data

Model	ZC-S51100			
Single Module Capacity	5.12KWh			
Module Number	1	2	3	4
Rated Capacity	5.12KWh	10.24KWh	15.36KWh	20.48KWh
Nominal Voltage	51.2V			
Working Voltage	44V-58.4V			
Nominal Discharging Current	100A	200A	300A	400A
Nominal Charging Current	50A	100A	150A	200A
Recommended Discharge Level	80%			
Humidity	20%-60%			
Installation Method	Stacked mode			
Protection Level	IP20			
Communication Protocol	CAN/RS485/RS232(WIFI optional)			
Dimension/module	600*440*200mm			
Net Weight/module	40kg			
<b>Battery Pack Parameters</b>				
Cell Type	LFP			
Battery Rated Input Voltage	51.2VDC			
Hybrid Charging Maximum Charging Current	80A			
Battery Pack Voltage Range	40VDC-60VDC			
<b>Photovoltaic Input Parameters</b>				
Maximum PV Open Circuit Voltage	500VDC			
PV Working Voltage Range	120V-500VDC			
MPPT Voltage Range	120V-450VDC			
Maximum PV Input Current	16A			
Maximum PV Input Power	5500W			